

UTILITY VENT SET
 UVS2, CLASS-1, INLET ACCESSORIES

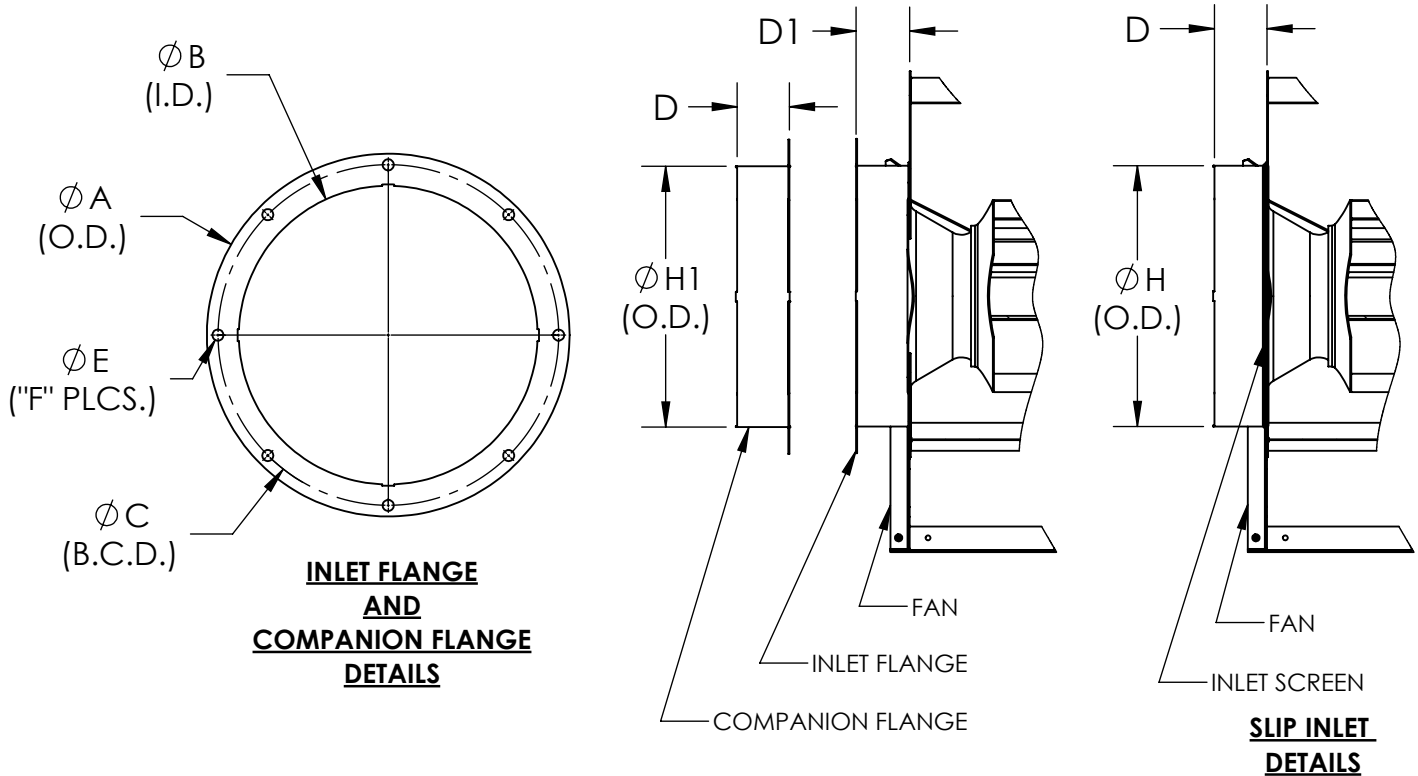

1. ALL ITEMS SHOWN ARE OPTIONAL.
2. INLET SCREEN TO BE MOUNTED USING VENTURI MOUNTING HARDWARES.
3. ID OF INLET COMPANION FLANGE = $\phi B + 0.375$

DIMENSIONAL DATA

Size	INLET FLANGE					D	D1	SLIP INLET	COMPANION RING
	O.D.	I.D.	B.C.D.	HOLE DIA.	HOLE QTY.			O.D.	O.D.
	A	B	C	E	F			H	H1
60	18.31	13.97	16.81	0.75	8	4.13	4.25	14.13	14.44
70	18.31	13.97	16.81	0.75	8	4.13	4.25	14.13	14.44
80	18.31	13.97	16.81	0.75	8	4.13	4.25	14.13	14.44
100	18.31	13.97	16.81	0.75	8	4.13	4.25	14.13	14.44
122	20.94	16.59	19.44	0.75	8	4.13	4.25	16.75	17.06
135	22.56	18.22	21.06	0.75	8	4.13	4.25	18.38	18.69
150	24.56	20.22	23.06	0.75	8	4.13	4.25	20.38	20.69
165	26.56	22.22	25.06	0.75	8	4.13	4.25	22.38	22.69
182	27.31	22.97	25.81	0.75	8	4.13	4.25	23.13	23.44
200	29.44	25.09	27.94	0.75	8	4.13	4.25	25.25	25.56
222	32.19	27.84	30.69	0.75	8	4.13	4.25	28.00	28.31
245	35.06	30.72	33.56	0.75	8	4.13	4.25	30.88	31.19
270	38.06	33.72	36.56	0.75	8	4.13	4.25	33.88	34.19
300	41.88	37.54	40.38	0.75	8	4.13	4.25	37.69	38.00
330	45.63	41.29	44.13	0.75	8	4.13	4.25	41.44	41.75
365	50.00	45.66	48.50	0.75	8	4.13	4.25	45.81	46.13
402	55.69	50.35	53.69	0.88	8	4.13	4.25	50.50	50.81
445	61.06	55.73	59.06	0.88	8	5.13	5.25	55.88	56.19
490	66.69	61.35	64.69	0.88	8	5.13	5.25	61.50	61.81
542	73.31	67.98	71.31	0.88	8	5.13	5.25	68.13	68.44

ALL DIMENSIONS ARE IN INCHES